

ROCK INJECTOR POINT

APF-R-12

Dimensions

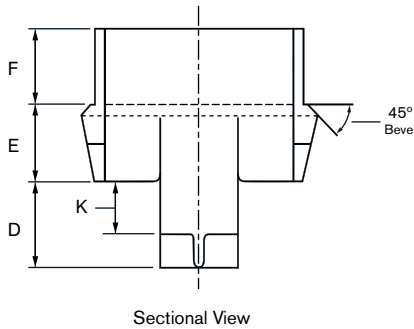
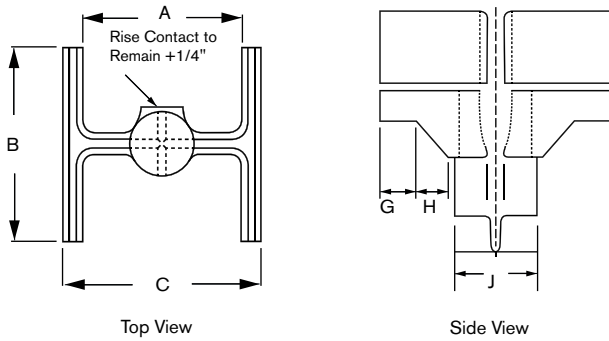

MATERIAL: CAST STEEL
 ASTM A148 90/60
 Weight 80#

12"			
A	9-3/4"	F	4"
B	12-1/4"	G	2"
C	12-1/4"	H	1-1/2"
D	4-1/2"	J	4"
E	4"	K	1-9/16"

NORMAL FOUNDRY TOLERANCES APPLY

Attachment Procedures

1. Fit point onto the end of the square cut pile end.
2. Weld point to the pile in either flat or vertical position using E70XX electrodes or equivalent filler material.
3. Weld across full width of flange following chart below for minimum size weld.

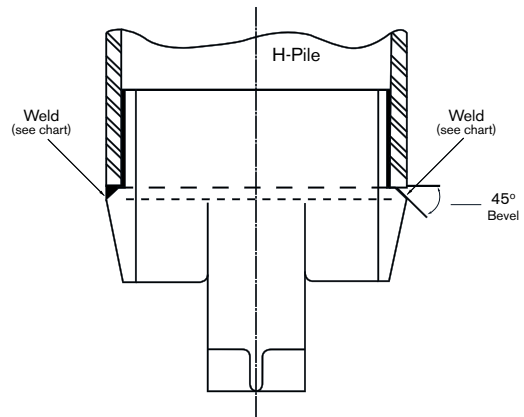

Pile Size	Flange Thickness	Groove Weld
HP 12 x 89	.720	3/8
x 84	.685	3/8
x 74	.610	3/8
x 63	.515	5/16
x 53	.435	5/16



**ASSOCIATED PILE
& FITTING**

45 Samworth Road, Clifton, NJ 07014
 Tel: 973-773-8400
 Fax: 973-773-8442
 email: apf@associatedpile.com
www.associatedpile.com
 Call Toll Free: 800-526-9047